



## TECHNICAL INFORMATION

# Piston Seals | Turcon® Glyd Ring® T

### Description

The Turcon® Glyd Ring® T is a very effective and reliable low frictional seal. The double acting Turcon® Glyd Ring® T is a combination of a Turcon® based slipper seal and an energizing O-Ring. It is produced with an interference fit which together with the squeeze of the O-Ring ensures a good sealing effect even at low pressure. At higher system pressures, the O-Ring is energized by the fluid, pushing the Turcon® Glyd Ring® T against the sealing face with increased force.

The benefits of the patented seal concept are provided by the innovative functional principle of the trapezoidal profile cross-section. Both lateral profile flanks are inclined so that the seal profile tapers towards the seal surface. The profile can

thus retain the robust and compact form typical of piston seals without losing any of the flexibility required to achieve a pressure-related maximum compression. The edge angle created by the special Glyd Ring® T cross-sectional form permits an additional degree of freedom and enables a slight tilting movement of the seal. The maximum compression is thus always shifted towards the area of the seal edge directly exposed to the pressure.

On the low-pressure edge of the seal, on the other hand, the Glyd Ring® T exhibits only zones with neutral strains without compressive or shearing loads, thus effectively reducing the danger of gap extrusion.

### Advantages

- Very good static leak-tightness
- Increased clearance possible (approx. +50%), depending on the operating conditions
- Low friction, no stick-slip effect. Simple groove design
- Minimum static and dynamic friction coefficient for a minimum energy loss and operating temperature
- Suitable for non-lubricating fluids depending on seal material for optimum design flexibility
- High wear resistance ensures long service life
- No adhesive effect to the mating surface during long period of inactivity or storage
- Suitable for most hydraulic fluids in relation with most hardware materials and surface finish depending on material selected
- Due to the larger extrusion gap, safe use even with contaminated media
- Installation grooves also to ISO 7425-2
- Available for many diameters from 10 to 250 mm



### Technical Data

Pressure	: Up to 50 MPa
Speed	: Up to 15 m/s
Temperature	: -30 °C to +200 °C (depending on O-Ring material)
Media	: Mineral oil based hydraulic fluids, flame retardant hydraulic fluids, environmentally safe hydraulic fluids (bio-oils), phosphate ester and others, depending on the seal and O-Ring material compatibility
Clearance	: The maximum permissible radial clearance $S_{max}$ is shown in the table on the next page as a function of the operating pressure and functional diameter.



## TECHNICAL INFORMATION

# Piston Seals | Turcon® Glyd Ring® T

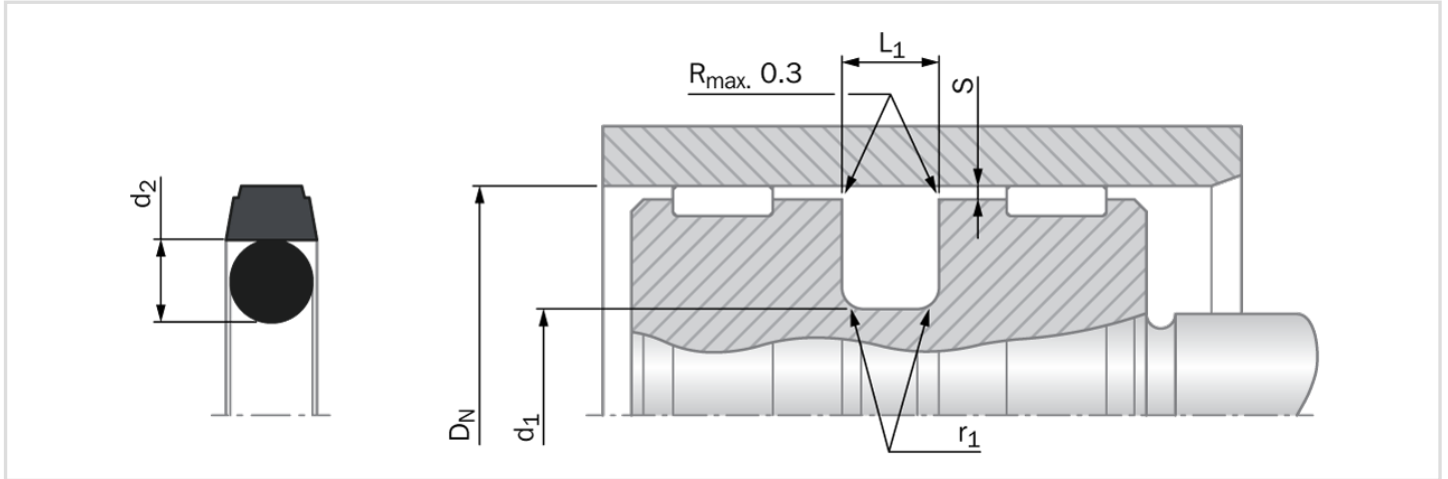

### Installation dimensions - Standard recommendations

Series No.	Bore Diameter D <sub>N</sub> H9			Groove Diameter d <sub>1</sub> h9	Groove Width L <sub>1</sub> +0.2	Radius r <sub>1</sub>	Radial Clearance S <sub>max</sub> *			O-Ring Cross-Section d <sub>2</sub>
	Standard Application	Light Application	Heavy Duty Application				10 MPa	20 MPa	40 MPa	
PT00	8 - 14.9	15 - 39.9	-	D <sub>N</sub> - 4.9	2.2	0.4	0.40	0.30	0.20	1.78
PT01	15 - 39.9	40 - 79.9	-	D <sub>N</sub> - 7.5	3.2	0.6	0.60	0.50	0.30	2.62
PT02	40 - 79.9	80 - 132.9	15 - 39.9	D <sub>N</sub> - 11.0	4.2	1.0	0.70	0.50	0.30	3.53
PT03	80 - 132.9	133 - 329.9	40 - 79.9	D <sub>N</sub> - 15.5	6.3	1.3	0.80	0.60	0.40	5.33
PT04	133 - 329.9	330 - 669.9	80 - 132.9	D <sub>N</sub> - 21.0	8.1	1.8	0.80	0.60	0.40	7.00
PT08	330 - 669.9	670 - 999.9	133 - 329.9	D <sub>N</sub> - 24.5	8.1	1.8	0.90	0.70	0.50	7.00
PT05	670 - 999.9	-	310 - 669.9	D <sub>N</sub> - 28.0	9.5	2.5	1.00	0.80	0.60	8.40
PT05X	-	1000 - 1200	-	D <sub>N</sub> - 28.0	9.5	2.5	1.00	0.80	0.60	8.40
PT06**	-	-	670 - 999.9	D <sub>N</sub> - 38.0	13.8	3.0	1.20	0.90	0.70	12.00
PT06X**	1000 - 2700	-	-	D <sub>N</sub> - 38.0	13.8	3.0	1.20	0.90	0.70	12.00

\* For pressures from 40 MPa to the maximum specified, use diameter tolerance H8/f8 (bore/rod) in the area behind the seal.

SlydRing®/Wear Rings are not applicable at very small radial clearance S.

\*\* O-Rings with 12 mm cross section are delivered as special profile ring.

### Important Note

Installation suggestions, material recommendations, parameters and further data provided are always subject to the particular field of use and the application in which the seal is intended to be used, in particular the interaction of the seal with other components of the application. Therefore they neither constitute an agreement on the legal and factual nature nor a guarantee of quality. Technical changes and errors remain reserved.